

### 3.3.1 TECHNICAL DATA

**MAX OPERATING PRESSURE (PS):** 60 bar

**PRESSURE TEST (PT):** 1.43 x PS

**NOMINAL CAPACITIES:**

0.7 - 1 - 1.5 - 3 - 5 - 10 - 15 - 20 - 25 - 35 - 55 litres

**WORKING TEMPERATURE:** -40 ÷ +150 °C

**COMPRESSION RATIO (Po : P2):** max. 1 : 4

**FLUID VISCOSITY RANGE:** 10 ÷ 400 cSt

**RECOMMENDED VISCOSITY:** 36 cSt

**FLUID CONTAMINATION DEGREE:**

class 21/19/16 according to ISO 4406/99

**BODY MATERIAL:**

- carbon steel shell painted with rust inhibitor RAL 8012
- nickel coating 25 - 40 µ
- stainless steel AISI 316L

**VALVES MATERIAL:**

- phosphated or galvanized carbon steel in compliance with Directive 2002/95/EC (RoHS) to resist to corrosion
- stainless steel AISI 316L
- nickel coating 25-40 µ

**BLADDER MATERIAL:**

- **P** = Nitrile rubber (NBR)
- **F** = Low temp. nitrile rubber
- **H** = Nitrile for hydrocarbons
- **K** = Hydrogenated nitrile (HNBR)
- **B** = Butyl (IIR)
- **E** = Ethylene-propylene (EPDM)
- **N** = Chloroprene (Neoprene)
- **Y** = Epichlorohydrin (ECO)
- **V** = Fluorocarbon (FPM)

See Table 3.3c and/or Chapter 1.5

**FILLING VALVE CONNECTION:**

- 5/8"-UNF std
- 7/8" UNF
- 1/4" BSP

**FLUID PORT CONNECTION:** see 3.3db - 3.3eb - 3.3ec - 3.3fb

**FLOW RATE:** see Table 3.3db

**WEIGHT:** see Table 3.3db

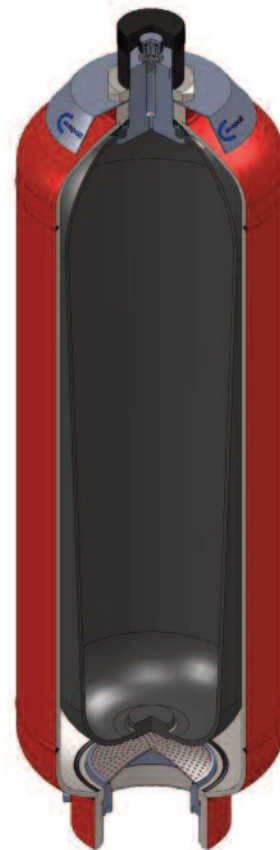

3.3a

### 3.3.2 HYDRAULIC SYMBOL

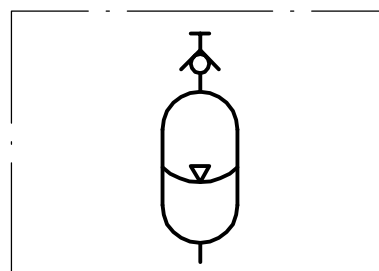

3.3b

### 3.3.3 “ASB” BLADDER ADVANTAGES

- dirt tolerant
- light weight
- compact
- simple construction
- quick response
- works well on water, low lubricity fluids
- quick, easy installation
- low cost

### 3.3.4 DESCRIPTION

Bladder low pressure type accumulators consist of a welded cylindrical pressure vessel made of steel.

The accumulator is subdivided into a gas and fluid side by an elastic bladder mounted in the interior of the vessel.

The bladder is charged with nitrogen to the specified gas charge pressure P0 by means of gas valve.

When the fluid is pressed into the accumulator, the gas in the bladder is compressed and hence the pressure increased. The gas volume reduces and on the fluid side, the fluid can flow into the accumulator. As soon as the pressure on the fluid side falls below the gas pressure, the accumulator is emptied.

The special oil valve (anti-extrusion plate) prevents draining of the bladder into the oil channel and thus the bladder from being destroyed.

When the minimum operating pressure is reached, a small oil volume is to be maintained between the bladder and the fluid volume (approx. 10% of the nominal capacity of the hydraulic accumulator), in order that the bladder does not hit the valve during every expansion process.

Gas valve consists of external caps, sealing cap, filling valve, gas valve body and rubber coated washer. These parts can be replaced separately.

The nameplate shows the technical data and features of the hydraulic accumulator.

### 3.3.5 EUROPE MARKET

All hydraulic accumulators are pressure vessels and are subject to the national regulations and directives, valid at the place of installation.

Bladder accumulator type ASB, up to and including 1 litre, must not be CE marked.

For bladder accumulator type ASB, greater than 1 litre, every shipping batch is complete of a conformity declaration and instruction of use and maintenance and/or all documents requested.

All vessel categories (see Table 3.3db) must be protected by means of a pressure relief valve in accordance with Directive 97/23/EC.

### 3.3.6 ACCESSORIES

For support equipment, see Cap. 7

For gas side's safety equipment, see Cap. 8

For fluid side's safety equipment, see Cap. 9

For pre-loading and charging set, see Cap. 11

For other components, see Cap. 12

### 3.3.7 BLADDER-TEMPERATURE-LIQUID COMPATIBILITY

When selecting the accumulator variant, pay attention to the following non-binding notes with regard to hydraulic fluid, bladder material and the permissible temperature range. (see Section 1.5)

Code letter	Polymer	ISO	Temperature range (°C)	Some of the liquids compatible with the polymer
P	Standard nitrile (Perburan)	NBR	-20 ÷ +80	Aliphatic hydrocarbons (propane, butane, gasoline, oils, mineral greases, diesel fuel, fuel oil, kerosene), mineral greases and oils, HFA - HFB - HFC fluids, many dilute acids, alkalis, saline solutions, water, water glycol.
F	Low temperature nitrile	NBR	-40 ÷ +70	The same as with standard nitrile + a number of different types of Freon. (This contains less acrylonitrile than the standard and is therefore more suitable for low temperatures, but its chemical resistance is slightly lower).
H	Nitrile for hydrocarbons	NBR	-10 ÷ +90	Regular and premium grade slightly aromatic gasoline (and all the liquids for standard nitrile).
K	Hydrogenated nitrile	HNBR	-30 ÷ +130	The same as with standard nitrile but with excellent performance at high and low temperatures.
B	Butyl	IIR	-30 ÷ +100	Hot water up to 100°C, glycol-based brake fluids, many acids and bases, salt solutions, polar solvents such as alcohols, ketones and esters, polyglycol-based hydraulic fluids (HFC fluids) and bases of esters of phosphoric acid (HFD-R fluids), silicone oils and greases, Skydol 500 and 7000, resistance to ozone, aging and weathering.
E	Ethylene-Propylene	EPDM	-30 ÷ +100	Hot water up to 100°C, glycol-based brake fluids, many organic and inorganic acids, detergents, solutions of sodium and potassium, phosphate ester-based hydraulic fluids, (HFD-R), silicone oils and greases, many polar solvents (alcohol, ketones, esters), Skydol 500 and 7000, resistance to ozone, aging and weathering.
N	Chloroprene (Neoprene)	CR	-30 ÷ +100	Mineral oils of paraffin, silicone oils and greases, water and aqueous solutions, refrigerants (ammonia, carbon dioxide, Freon), naphthenic mineral oils, low molecular aliphatic hydrocarbons (propane, butane, fuel), brake fluids based on glycol, better resistance to ozone, weathering and aging compared to NBR rubber.
Y	Epichloridrin	ECO	-30 ÷ +110	Mineral oils and greases, aliphatic hydrocarbons (propane, butane and gasoline), silicone oils and greases, water at room temperature, resistance to ozone, aging and weathering.
V	Fluorocarbon	FPM	-10 ÷ +150	Mineral oils and greases, non-flammable fluids of HFD group, silicone oils and greases, animal and vegetable oils and greases, aliphatic hydrocarbons (gasoline, butane, propane, natural gas), aromatics hydrocarbons (benzene, toluene), chlorinated hydrocarbons (Tetrachloroethylene, carbon tetrachloride), fuel (regular, super and containing methanol), excellent resistance to ozone, weathering and aging.

For other hydraulic fluid and/or temperatures, please consult us.



3.3.8 ORDER CODE

1	2	3	4	5	6	7-8	9	10	11	12	13	14	15	16	
ASB	55	P	30	C	R	G9	V	-	8	-	X	1	X	0	G30 / 10

**1 Series**  
Bladder accumulator low pressure = **ASB**

**2 Nominal capacity**

0.2 lt =	<b>0.2</b>
0.7 lt =	<b>0.7</b>
1 lt =	<b>1</b>
1.5 lt =	<b>1.5</b>
3 lt =	<b>3</b>
5 lt =	<b>5</b>
10 lt =	<b>10</b>
15 lt =	<b>15</b>
20 lt =	<b>20</b>
25 lt =	<b>25</b>
35 lt =	<b>35</b>
55 lt =	<b>55</b>

**3 Bladder material**

Nitrile rubber (NBR)	=	<b>P</b>
Nitrile for low temp.	=	<b>F</b>
Nitril for hydrocarbons	=	<b>H</b>
Hydrogenated nitrile (HNBR)	=	<b>K</b>
Butyl (IIR)	=	<b>B</b>
Ethylene-propylene (EPDM)	=	<b>E</b>
Chloroprene (Neoprene)	=	<b>N</b>
Epichlorohydrin (ECO)	=	<b>Y</b>
Fluorocarbon (FPM)	=	<b>V</b>

**4 Max working pressure (PS)**  
See the table on front page

**5 Body material**

Carbon steel	=	<b>C</b>
Nickel coated carbon steel 25 μ	=	<b>N</b>
Nickel coated carbon steel 40 μ	=	<b>M</b>
Stainless steel	=	<b>X</b>

**6 Fluid port connection**

0.7÷55 I BSP ISO 228 with chamfer for OR (std)	=	<b>A</b>
0.7÷55 I adapter *	=	<b>R</b>

\* assembled on the fluid valve connection type A

**7-8 Dimension of the connection fluid or 7+8 table**  
See the table on front page

**16 Precharge pressure (bar)**  
Standard 10 bar = **0 ÷ 15** (< PS)

**15 Other variants**  
See the table on front page

**14 Variants of gas side**

Standard	=	<b>0</b>
Only cap in stainless steel	=	<b>1</b>
Brass nameplate	=	<b>2</b>

Other numbers/variants to be requested EPE

**13 Gas valve material**

Carbon steel	=	<b>C</b>
Nickel coated carbon steel 25 μ	=	<b>N</b>
Nickel coated carbon steel 40 μ	=	<b>M</b>
Stainless steel	=	<b>X</b>

**12 Variants of fluid side**

Standard	=	<b>0</b>
Adapter in stainless steel (R)	=	<b>1</b>
Button and spring in stainless steel	=	<b>2</b>

Other numbers/variants to be requested EPE

**11 Fluid valve material**

Carbon steel	=	<b>C</b>
Nickel coated carbon steel 25 μ	=	<b>N</b>
Nickel coated carbon steel 40 μ	=	<b>M</b>
Stainless steel	=	<b>X</b>

**10 Test and certification**

Factory testing	=	<b>0</b>
TR (Russia)	=	<b>1</b>
ML (China)	=	<b>3</b>
PED97/23/EC(for capacities greater than 1 l)	=	<b>8</b>
ATEX 94/9EC	=	<b>9</b>
RTN Passport (Ukraine)	=	<b>11</b>
Algeria passport	=	<b>12</b>
Standard regulation (NR13) (Brazil)	=	<b>13</b>
Tunisia passport	=	<b>14</b>

**9 Connection gas side**

Standard filling valve 5/8" UNF thread	=	<b>V</b>
Standard filling valve with 5/8" UNF thread in stainless steel	=	<b>VX</b>
Without filling valve (thread hole M12x1.5)	=	<b>V0</b>
Brass filling valve 1/4" BSP	=	<b>V2</b>
Filling valve 7/8" UNF	=	<b>V4</b>

Special variants upon request



4 Max working pressure (PS)		
Capacity litres	Carbon steel	Stainless steel
0.7 ÷ 5	<b>60</b>	<b>40</b>
10 ÷ 55	<b>30 - 50</b> (other pressure related to connections B or U)	<b>25 - 50</b>

15 Other variants	
Adapter + Burst disc set at xxx bar (see Section 8.2)	= <b>Rxxx</b>
Adapter + Safety valve, type VS224TX set at xxx bar	= <b>Gxxx</b>
Adapter + Needle Valve of 1/4" BSP	= <b>EG2</b>
Adapter + Stainless steel needle Valve of 1/4" BSP	= <b>EG2X</b>
Adapter + Excluding device with with full scale pressure gauge of xxx bar	= <b>EMxxx</b>
Adapter + Excluding device of 90° with full scale pressure gauge of xxx bar	= <b>ELMxxx</b>
Flushing with degree of contamination ≤ x (NAS)	= <b>Fx</b>
75-80 µ thick. polyurethane paint with colour to be specified	= <b>Wxxx</b>
Off-shore paint with colour to be specified	= <b>Zxxx</b>
NORSOK System 1 paint with colour to be specified	= <b>K1</b>
NORSOK System 7 paint with colour to be specified	= <b>K7</b>
other variants upon request	

7 Dimension of the fluid connection	
For the type of connection:	
A (0.7 ÷ 5 l) 2"	= <b>9</b>
(3 ÷ 5 l) 2" 1/2	= <b>10</b>
(10 ÷ 55 l) 4"	= <b>13</b>
B (0.7÷55 l)	<b>DIMENSION/RATING</b>
Former. 1" ANSI 150 = 1/150 (Pmax = 20 bar)	
U (0.7÷55 l)	<b>DN/PN</b>
Former. DN50 PN16 = 50/16 (Pmax = 16 bar)	
R (0.7÷55 l) Blind	= <b>0</b>
R (0.7÷55 l) internal thread	= <b>G*</b>
BSP ISO 228	= <b>P*</b>
NPT-F	= <b>N*</b>
BSPT	
SAE	= <b>S*</b>
Metric	= <b>M*</b>
*Variant in table 8	

8 Dimension		
1/8" = <b>1</b>	3/4" = <b>5</b>	2" = <b>9</b>
1/4" = <b>2</b>	1" = <b>6</b>	2" 1/2" = <b>10</b>
3/8" = <b>3</b>	1" 1/4" = <b>7</b>	3" = <b>11</b>
1/2" = <b>4</b>	1" 1/2" = <b>8</b>	3" 1/2" = <b>12</b>

Dimension in inch - No.of pitch for inch  
 Diameter/pitch

Special variants upon request

3.3.9 DIMENSIONS

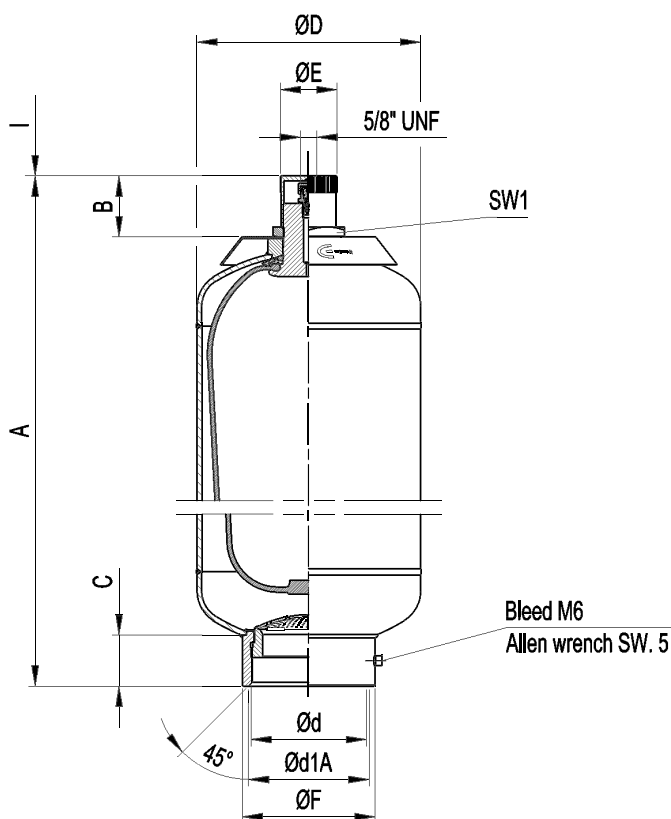

3.3da

Acc. type ASB in carbon steel	Nominal gas volume litres	Effective gas volume litres	Working pressure bar	Ped category liquids of group 2	Max.diff. pressure P2-P1 bar	Flow rate l/min	Max.comp. ratio P0/P2	A mm	B mm	C mm	Ø D mm	Ø d BSP	Ø d1 mm	Ø E mm	Ø F mm	I mm	SW 1 mm	Acc. dry weight kg
ASB 0.7	0.7	0.7	60 (40)	I	5	100	1:4	235 ±3	47	46	89	1" 1/2	54	25	60	140	32	2.4
ASB 1	1	1	60 (40)	I	5	100	1:4	253 ±3	45	41	114	1" 1/2	54	25	60	140	32	4.2
ASB 1,5	1,5	1,5	60 (40)	I	5	100	1:4	330 ±3	47	45	114	2"	63.35	25	75	140	32	4.8
ASB 3	3	2,95	60 (40)	II (I)	5	100	1:4	510 ± 5	47	45	114	2"	63.35	25	75	140	32	5.5
ASB 5	5	5	60 (40)	II (I)	5	150	1:4	420 ± 10	47	46	168	2" 1/2	79	25	88	140	32	11
ASB 10	10	9,1	30 (25+50)	I	5	300	1:4	475 ± 10	60	50	219	4"	118.4	55	130	140	70	18
ASB 15	15	14,5	30 (25+50)	I	5	300	1:4	615 ± 10	60	50	219	4"	118.4	55	130	140	70	23
ASB 20	20	18,2	30 (25+50)	I	5	300	1:4	755 ± 10	60	50	219	4"	118.4	55	130	140	70	28
ASB 25	25	23,5	30 (25+50)	I	5	300	1:4	900 ± 15	60	50	219	4"	118.4	55	130	140	70	33
ASB 35	35	33,5	30 (25+50)	I	5	300	1:4	1285 ± 15	60	50	219	4"	118.4	55	130	140	70	47
ASB 55	55	50	30 (25+50)	I	5	300	1:4	1765 ± 15	60	50	219	4"	118.4	55	130	140	70	65

\* Allen wrench

\*\* Ex. wrench

3.3db

\* The maximum differential pressure is the maximum allowable difference between the maximum pressure and the minimum working pressure (P2-P1) to have an infinite life cycle of the accumulator (greater than 2,000,000 cycles).

\*\* Flow rate measured using mineral oil with viscosity of 36 cSt at 50°C and ΔP = 5 bar

3.3.9.1 FLANGE CONNECTION  
TYPE ANSI / UNI DIN (B/U)

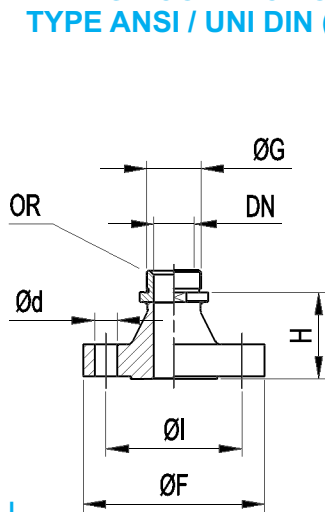

Fig. I

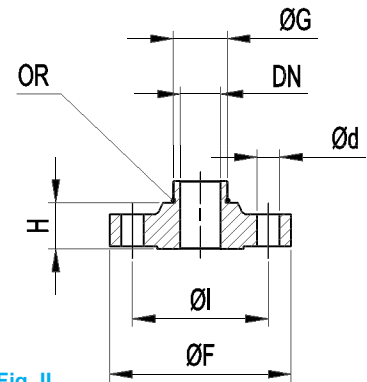
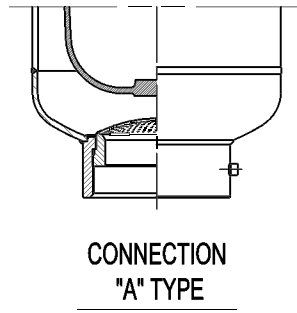

Fig. II

3.3ea

	Accumulator type	Spare flange order code	Ref. Directive		DN mm	PN bar	Fig.	Ø F mm	Ø I mm	Ød mm	N° Holes	H mm	G BSP	OR (Included)
			UNI	DIN										
U (UNI-DIN)	ASB 0.7 - 1	-	-	-	On request								-	-
	ASB 1.5 - 3	F 2222 - ** / *	2284	2635	25	40	I	115	85	14	4	51	2"	0010R3218-*
		F 2227 - ** / *	2284	2635	40	40	I	150	110	18	4	56		
		F 2231 - ** / *	2282	2633	50	16	II	165	125	18	4	23		
	ASB 5	F 2232 - ** / *	2285	2636	65	64	II	185	135	22	4	40	2" 1/2	0010R3281-*
		F 2241 - ** / *	2282	2633		16		185	145	18	4	23		
	ASB 10 ÷ 55	F 2242 - ** / *	2284	2635	50	40	I	165	125	18	4	65	4"	0010R4425-*
		F 2255 - ** / *	2282	2633		16		165	125	18	4	68		
		F 2256 - ** / *	2284	2635	80	16	II	200	160	18	8	70		
		F 2259 - ** / *	2282	2633	100	16		220	180	18	8	31		
		F 2261 - ** / *	2284	2635	40	235	190	22	8	44				

\* Gasket material

\*\* Flange material

Others size on request

3.3eb

	Accumulator type	Spare flange order code	Ref. Directive	DN inch	PN lbs	Fig.	Ø F mm	Ø I mm	Ød mm	N° Holes	H mm	G BSP	OR (Included)
ASB 1.5 - 3	F 2225 - ** / *	B16.5	B16.5	1"	300	I	123,5	88,9	19	4	73	2"	0010R3218-*
	F 2229 - ** / *	B16.5	B16.5	1" 1/2	300	I	155,6	114,3	22,2	4	79		
	F 2235 - ** / *	B16.5	B16.5	2"	400	II	165	127	19	8	55		
ASB 5	F 2243 - ** / *	B16.5	B16.5	2" 1/2	150	II	177,8	139,7	19	4	45	2" 1/2	0010R3281-*
	F 2244 - ** / *	B16.5	B16.5		300		190,5	149,2	22,2	8	52		
ASB 10 ÷ 55	F 2257 - ** / *	B16.5	B16.5	2"	150	I	152,4	120,6	19	4	84	4"	0010R4425-*
	F 2258 - ** / *	B16.5	B16.5		300		165,1	127	19	8	90		
	F 2263 - ** / *	B16.5	B16.5	4"	150	II	228,6	190,5	19	8	46		
	F 2264 - ** / *	B16.5	B16.5		300		254	200	22,2	8	60		

\* Gasket material

\*\* Flange material

Others size on request

3.3ec

3.3.9.2 ADAPTERS

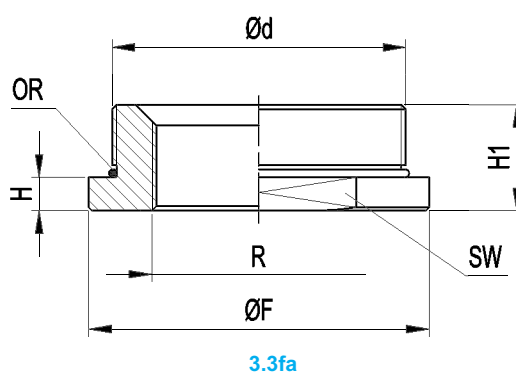

Accumulator type	Order code	Ød Acc. connection	R**** Out connections (0 = blind)	SW mm	Ø F mm	H mm	H 1 mm	OR ( Included )	Weight Kg
ASB 0,7 - 1	R - A8*** - ** / *	1" 1/2 BSP	1/8" + 1" 1/4 BSP - NPT - BSPT	65	70	15	45	0010R0156 - *	0,6
ASB 1,5 - 3	R - A9*** - ** / *	2" BSP	1/8" + 1" 1/2 BSP - NPT - BSPT	70	75	11	35	0010R3218 - *	0,86
ASB 5	R - A10*** - ** / *	2" 1/2 BSP	1/8" + 2" BSP - NPT - BSPT	80	88	20	44	0010R3281 - *	1,3
ASB 10 + 55	R - A13*** - ** / *	4" BSP	1/8" + 3" 1/2 BSP - NPT - BSPT	120	130	14	35	0010R4425 - *	3

\* Gasket material

\*\* Adapter material

\*\*\* See chapter 3.3.8 table 7 - 8

Weigth indicated only for blind version

3.3fb

\*\*\*\* R Out connections type "S" and "M" thread on request



3.3.10. SPARE PARTS CODE

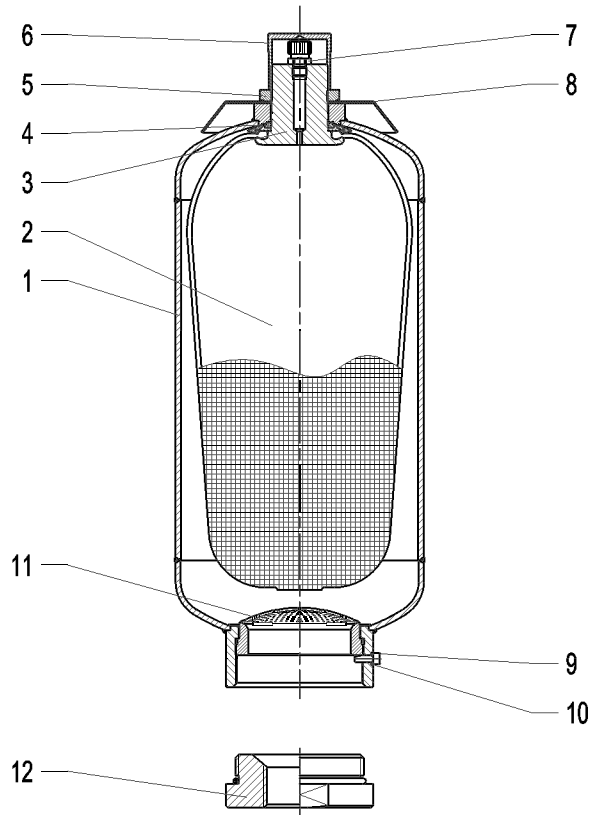

3.3ga

Item	Description	Q.ty	Type			
			ASB 0,7	ASB 1-1,5 - 3	ASB 5	ASB 10 ÷ 55
1	Accumulator shell	1	Not supplied as spare part			
2	Bladder	1	S0,7* - 0	S1* - 0 / S1.5* - 0 / S3* - 0	S5* - 0	S10 + 55* - 0
3	Gas valve body	1	B10107 - **		B10202 - **	B10333 - **
4	Rubber-coated washer	1	B10104 - ** / *	B10106 - ** / *	B10205 - ** / *	B10334 - ** / *
5	Gas valve looknut	1	B10109 - **			B10302 - **
6	Protection cap	1	B10103 - **			B10301 - **
7	Gas fill valve	1	V 2072 - ** - *			
8	Name plate	1	D10300A-A		D10300C-A	D10300E-A
9	Bleed screw	1	B10316 - **			
10	Seal ring	1	B10336 - R			
11	Anti-extrusion plate	1	B11426A - **1	B10159A - **1	B10241A - **1	B10421A - **
12	Adapter	1	See chapter 3.3.9.2 ADAPTER			
Standard gas valve ass. (parts 3 ÷ 7)		1	V 2021 - ** / *	V 2022 - ** / *	V 2042 - ** / *	V 2062 - ** / *
Gasket sets		1	B2082-* { 0010R2050-* B10341-P B10342-P 0010R4425-* B10336 - R }	B2032 - * { 0010R2050-* B10341-P B10342-P 0010R3218-* B10336 - R }	B2052-* { 0010R2050-* B10341-P B10342-P 0010R3281-* B10336 - R }	B2082-* { 0010R2050-* B10341-P B10342-P 0010R4425-* B10336-R }

\* Gasket material      \*\* Component material

3.3gb

### 3.3.11 COMMISSIONING AND MAINTENANCE

#### Delivery conditions

Bladder accumulators type ASB are delivered pre-charged with nitrogen at a pressure of 10 bar or at value of pressure required at time of order. The pre-charge value is also on the nameplate of the accumulator.

Depending on the size and quantity ordered, the bladder accumulators are shipped in boxes, in cartons, on pallets or wooden boxes on request. Unless otherwise required, certificates and documentation are provided together with the accumulators.

#### Handling

The original packaging is suitable for handling and general storage. Where necessary, you should use suitable lifting equipment to support the weight of the accumulators.

However protect from impact the packaging and handle it with care.

#### Storage

During storage in the warehouse, leave the product in its original packaging, keeping it away from heat sources and naked flames. The storage temperature should be between +10 and +40°C.

In addition to six months of storage, the precharge pressure must be to two bar and make sure that inside there is lubrication fluid compatible with bladder polymer.

After six years of storage, it is essential to proceed with the replacement of all elastomeric parts before the commissioning.

#### Marking on the nameplate of the accumulator

With reference to the PED 97/23/EC classification, Article 3, Paragraph 3 and / or risk categories I or II depending on the volume and maximum working pressure, the accumulator indicates the following data:

- Logo, name and country of the manufacturer
- Month/year of production
- Product code
- Serial number
- Maximum PS pressure and PT test pressure in bar
- Min. and max. TS working temperature in Celsius
- Volume V in litres
- Group of fluids allowed (II)
- CE marking (for volumes exceeding 1 litre) with the identification number of the notified body
- Pre-charge pressure in bar

#### It is strictly forbidden to:

- weld, rivet or screw any item of the accumulator
- engrave or permanently stamp the surfaces of the accumulator shell and / or carry out other operations that could affect or change the mechanical properties of the accumulator
- use the accumulator as a structural element: it should not be subjected to stresses or loads
- change the data of the nameplate and / or accumulator without the permission of the manufacturer
- use a (dangerous) fluid of Group 1 with equipment designed and manufactured for fluids of Group 2.

#### Installation

Before installation, you must perform a visual check to verify that the accumulator has not suffered any damage during shipping / handling.

Verify that the requested type matches with what stamped on the nameplate. We recommend using the accumulator with a suitable security valve (see Chapter 8) or a security block type BS (see Chapter 9). This device provides user and equipment protection against possible damage caused by pressure surges and also makes the maintenance of the accumulator easier, facilitating the interception and the discharge. Provide for a space of 200 mm above the gas pre-charge valve to allow access to and control of the pre-charge equipment (see Chap.11.1). The accumulators type ASB may be installed in any position from horizontal to vertical (preferably with the pre-charge valve at the top), and the nameplate must be visible. Proceed to the assembly so that no abnormal force affects the pipes connected directly or indirectly to the accumulator, so we recommend the use of supporting components and also fastening (please see Chapter 7) to avoid the transmission of vibrations. If are not used EPE safety blocks, make sure that the accumulator is connected to the hydraulic circuit by suitable connection devices. Make sure the fluid is compatible with the elastomer of the bladder. Check that the max. allowed accumulator pressure is equal to or greater than that of the hydraulic circuit and that the temperature during operation is maintained within the range expected. Make sure the fluid does not contain contaminants and/or abrasive.

#### Pre-charge of nitrogen

Normally, the bladder accumulators are delivered pre-charged with pressurized gas. The pre-charge of gas can be controlled and / or adjusted before or after installation of the accumulator in the hydraulic circuit.

For the pre-charge, use only industrial dry nitrogen with a purity of min. 99%. It is important to use the nitrogen from a bottle equipped with a pressure reducing valve (see Chap.11.3). Use the EPE pre-charge and charging set type PC to check the charging pressure required, and adjust if necessary. If the pre-charge pressure is lower than required, connect the harging hose on one side and the other side connect it to the nitrogen bottle or to the pressure reducer. Slowly fill the nitrogen in the accumulator until reaching a pressure slightly higher than that set value (+ 10 ÷ 15%). Close the bottle and remove the charging hose from the pre-loading set; wait until the gas temperature has stabilized (2 hours) and calibrate the pressure, discharging the excess gas. Make sure that the gas valve is not subject to losses and, if necessary, use soap and water.

Tighten the protective caps manually.

#### Hydraulic pressurization

- Check that the pre-charge pressure is adequate for the application
- Ensure that the hydraulic pressure never exceeds the max pressure allowed (PS) shown on the accumulator shell.

To avoid this risk, use a safety device (see Chap. 9).

#### Maintenance

- Periodically check the pre-charge pressure of the gas: after the commissioning, check after 2-3 weeks of operation and if there were no leaks, repeat the operation after 3 months; if the pressure at the same temperature was stable, repeat the test yearly. For heavy-duty applications, check the pre-charge every 6 months.
- Periodically (yearly) carry out a visual inspection of the accumulator in order to detect any early signs of deterioration such as corrosion, deformation, etc.
- Comply with the requirements of the regulations concerning the verification of the functionality of the equipment according to the country of installation of the accumulator.

### Repair

If for failure, scheduled check or retest it is necessary to remove the accumulator from the system, prior to removal, isolate the accumulator from the installation and discharge pressure of the liquid.

All bladder EPE accumulators of the ASB series may be repaired.

It may consist in replacing the bladder, the seals, the pre-charge valve and/or the parts of the gas and fluid valve.

For reasons of functionality and security, it is recommended to use only original spare parts.

### Disassembly

- Fasten the accumulator firmly in a vice or on a bench in a horizontal position, taking care not to damage the outer surface.

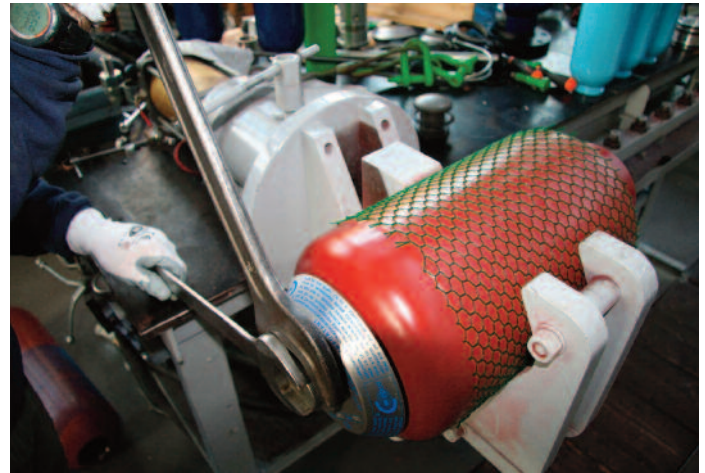

3.3l

- Remove gas valve, fastening the nut on the gas valve and remove the nameplate



3.3h

- If you have not already carried out, unscrew the cap nut first and then the valve cap of the gas valve.



3.3m

- Unscrew the vent screw



3.3i

- Allow gas escapes from the bladder with the help of the check valve until a pressure of 0 is displayed. Check if the bladder is now de-pressurizing an open valve.



3.3n

- Using a suitable wrench, unscrew the fluid valve (anti-extrusion plate)





3.3o

- Remove the oil valve

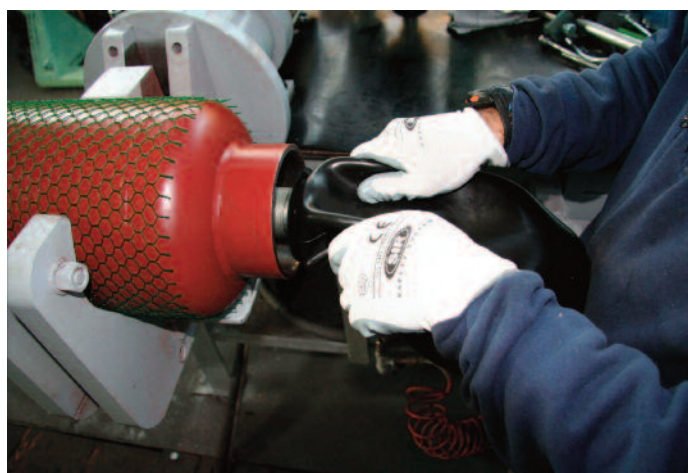

3.3q

- Drain air from bladder by pressing together



3.3p

- Fold bladder somewhat and withdraw by turning it slightly

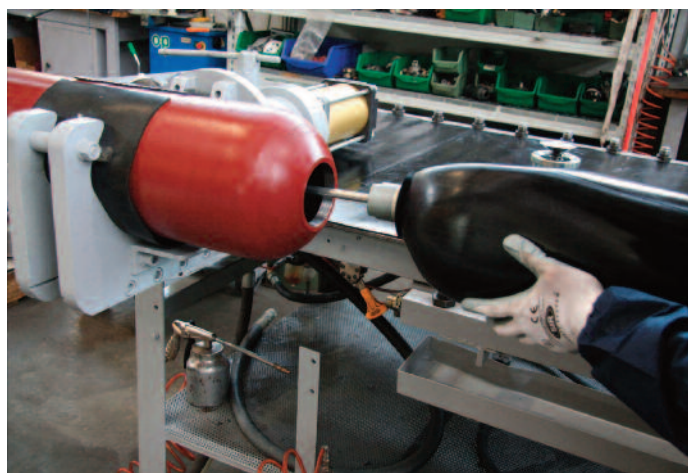

3.3r

- Carefully moisten the inside of the bladder and the container with used medium (roll container)

**Refitting**

Tightening torques in Nm			
	0.7-1.5 l	3 - 5 l	10-55 l
Fluid port ring nut	100 +20	200 +50	450 +50
Bleed screw	5 +1	5 +1	30 +10
Gas valve locknut	80 +20	100 +20	150 +30
Filling valve V - VX - V2	30 +5	30 +5	30 +5
Valve insert V4	0.3 +0.,2	0.3 +0.2	0.3 +0.2

- Cleaning and testing: clean all metallic parts on accumulator using an organic reducer – visual inspection of valves– Clean bladder, i.e. using isopropanol. Visual inspection of bladder for faults – inner inspection of container for signs of corrosion. In event of coated containers, check the condition of the coating. Replace the parts deemed to be bad; the o-rings must always be replaced (see spare parts Section 3.3.9).



3.3s

- Install the anti extrusion plate.



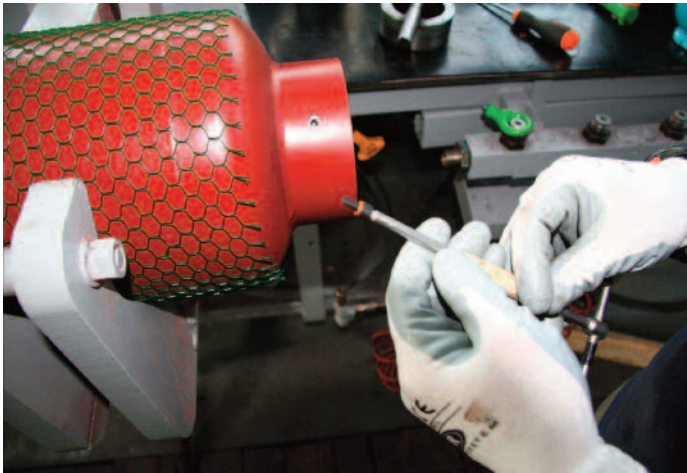

3.3t

- Mount the bleed screw with its sealing ring

### Pre-charge



3.3z

- Screw the pre-charge PC equipment on the gas valve.
- Connect the equipment to the cylinder of nitrogen or to the pressure reducer with the inflation tube.
- Slowly enter the nitrogen in the accumulator until reaching a pressure slightly higher than the set value (+ 10 ÷ 15%).
- Close the cylinder and remove the connecting pipe from the equipment.
- Wait until the gas temperature has stabilized (2 hours).
- Calibrate the pressure discharging the excess gas.

Make sure that the gas valve is not subject to losses and, if necessary, use soap and water.

Tighten the protective caps manually.



3.3u

- Tighten the hexagon nut SW1 on the gas valve

### Demolition and recycling of the accumulator

Before accumulator demolition or recycling, you should always discharge completely the pre-charge pressure and remove the gas valve.

If needed, proceed decontaminating in relation to the fluid used prior to demolition.



3.3v

- Mount the filling valve

### 3.3.12 REPAIR TOOLS

#### 3.3.12.1 BLADDER PULL ROD

The pull rod screwed to the gas valve of the bladder for easy assembly into shell during reassembly. Pull rod is complete with fitting for EPE gas valve and 3 extension segments to accommodate all size of accumulators.

Code for complete kit: **B2505**

#### Dimension

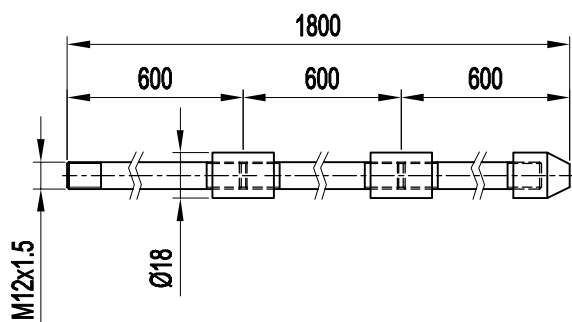

3.3aa

#### 3.3.12.3 CORE TOOL

The core tool is used to remove and reinstall the valve core type V4. Code **B2508**

#### Dimension

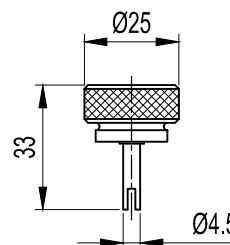

3.3ac

#### 3.3.12.2 LIFTING HOOK

To be used for the safe lifting of mounted accumulators:

For accumulators 0,7÷5 lt (M22x1,5) code **B2507/2**

For accumulators 10÷55 lt (M50x1,5) code **B2507/5**

For accumulators type V4 (7/8" UNF) code **B2507/7**

#### Dimension

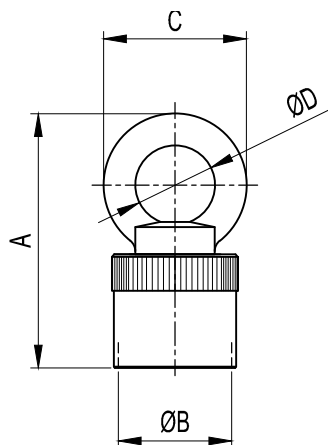

3.3ab

CODE	A	ØB	C	ØD	For Accumulator
B2507/2	100	M22x1.5	63	35	0.7 ÷ 1.5
B2507/5	112	M50x1.5	63	35	3 ÷ 5
B2507/7	100	7/8" UNF	63	35	10 ÷ 55