

TrΔle®

Hydraulic motors

Hydraulic motors

MOMT type motors

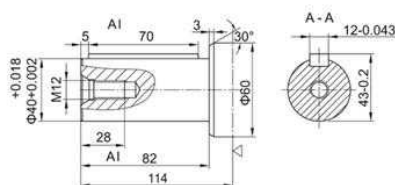
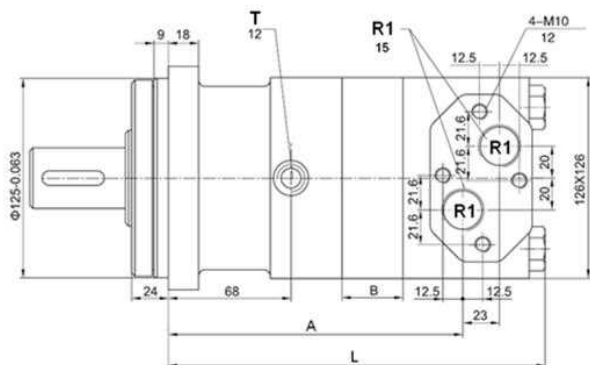
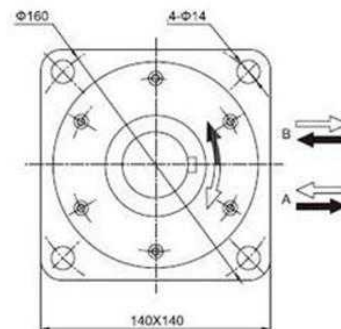

Shaft: cylindrical shaft, diameter 40 mm

R1=3/4"

Max. flow interm.: MOMT160 =125 (l/min); Others=150 (l/min)

Max. flow cont.: MOMT160 =100 (l/min); Others=125 (l/min)

T: drainage line, thread 1/4"

Power in kW. Torque in daN.m

Part n°	R1	Max. flow (l/min)	Max. press. cont.	Max. Peak press.	cm ³ / rev	R.P.M. cont.	R.P.M. int.	Max. torque cont.	Max. torque peak	Max. power cont.	A	B	L
MOMT160	3/4"	100	200	280	160	615	770	47	67	27	150	12	201
MOMT200	3/4"	125	200	280	200	615	750	58	83	34	155	16,5	205,5
MOMT250	3/4"	125	200	280	250	495	600	73	102	33,5	160	22	211
MOMT315	3/4"	125	200	280	315	375	455	94,8	133	33,4	167	29	218
MOMT400	3/4"	125	180	240	400	300	360	107,8	144	30	176	38	227
MOMT500	3/4"	125	160	210	500	235	285	122	159,9	26,4	195	56,5	245,5

*** Review attached PDF***

*Intermittent operation rating applies to 6 seconds of every minute.

*Peak load rating applies to 0.6 seconds of every minute.